

# Partner Elite (PEKP) Keypad & Intercom Station

## Installation Instructions

### 1. Introduction

The Partner Elite keypad is for use on P-16128 v3.1 and higher. The Partner Elite presents system status via a 32-character liquid crystal display. Each keypad is connected to the panel via the 4-wire Combust. In addition to regular keypad functions, the Elite can be used to initiate or receive pages, answer incoming calls, answer the doorbell, monitor rooms, or sound an alarm follower. To use the audio portion of the unit, each keypad must be home run to the PC4936 audio interface module using shielded 22 gauge, 4 conductor wire.

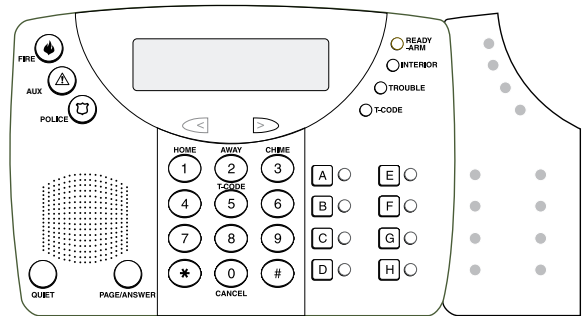

### 2. Specifications

- Connects to control panel via 4-wire Combust
- Current draw (from Combust): 50mA (standby), 100mA (with backlighting boost)
- Current draw (from PC4936): 20mA (standby), 50mA (max.)
- Thirteen programmable function keys (Home, Away, Chime, T-Code, Cancel, A to H)
- Eight programmable two-color LEDs
- Three emergency keys (Fire, Auxiliary, Police)
- Four status lights: Ready-Arm, Interior, Trouble, and T-Code
- Built-in intercom station with speaker, microphone, Page/Answer button, and Quiet (do not disturb) button

### 3. Installation

#### Unpacking

The Partner Elite package includes the following parts:

- One Partner Elite (PEKP) keypad
- Four mounting screws
- One inner-door sticker

#### Mounting

Mount the keypad where it is accessible to designated points of entry/exit. Once a dry and secure location is selected, perform the following steps to mount the keypad:

1. Remove the keypad backplate by loosening the screw located at the base of the unit.
2. Secure the keypad backplate to the wall in the desired location. Use the screws provided.

Before mounting the keypad to its backplate, complete keypad wiring as described over.



PARTNER PREMIER  
SERIES™

*Please refer to the System Installation Manual for information on limitations regarding product use and function and information on the limitations as to liability of the manufacturer.*

## Wiring

Before beginning to wire the unit, ensure that all power (AC transformer and battery) is disconnected from the control panel.

- Connect the four Combus wires (red, black, yellow and green) to the keypad terminals (R B Y G). Consult the diagram below.
- Use shielded wire to connect the +, -, S and M terminals to the PC4936 Audio Interface module, as shown below.
- When you have finished the wiring, mount the keypad on its backplate.

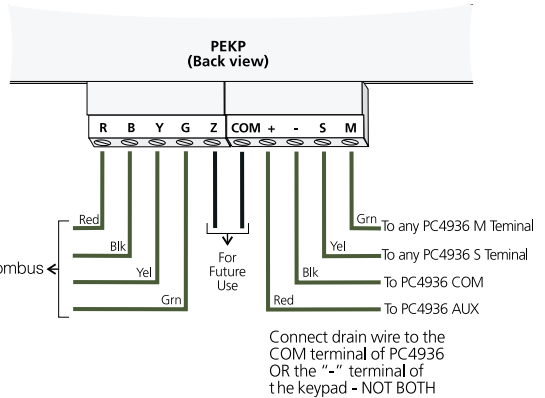

## Applying Power

Once all wiring is complete, apply power to the control panel. Connect the battery leads to the battery, then connect the AC transformer. For more information on control panel power specifications, see the control panel *Installation Manual*.

**NOTE:** Do not connect the power until all wiring is complete.

## 4. Enrolling the Keypad

Once all wiring is complete, you must enroll the keypad on the system. For instructions on enrolling keypads, see your *P-16128 Installation Manual*.

## 5. Programming the Keypad

Various programming items affect the operation of the keypad. See your *P-16128 Installation Manual* for descriptions of the programmable features. See your *PC4936 Installation Manual* for information on audio station functions and programming. You may want to program the following options:

- Partition and global keypad options
- Keypad toggle options
- Keypad time-out
- Keypad blanking
- Keypad - audio port assignment
- Fire, Medical and Police key programming
- Keypad lockout
- Keypad tampers
- Function keys: To alter the default setting of the function keys their default settings, see the list of available options in the *P-16128 Installation Manual*.
- Programmable two-color LEDs

## 6. Volume and Sensitivity Settings

There are two potentiometers on each keypad that control the speaker volume and microphone sensitivity (one potentiometer for each). Turning the speaker potentiometer clockwise increases the volume, turning it counter-clockwise decreases the volume. Turning the microphone potentiometer clockwise increases the sensitivity, turning it counter-clockwise decreases the sensitivity. The drawing shows the placement of the potentiometers.

